



INSTALLATION INSTRUCTIONS FOR PART 99-9011

Applications

VW

**CC 2009/EOS 2007-09/New Jetta 2005-09
GLI 2008-09/GTI 2006-09/Passat 2006-09
Rabbit 2006-09/R32 2008-09/Tiguan 2009**

99-9011

KIT FEATURES

- DIN Head Unit Provision with pocket
- ISO Head Unit Provision with pocket
- Double DIN Head Unit Provision
- ISO Stacked Head Unit Provision



KIT COMPONENTS

A) Radio Housing • B) ISO Brackets • C) ISO Trim Plate • D) DDIN Brackets • E) DDIN Trim Plate • F) Pocket

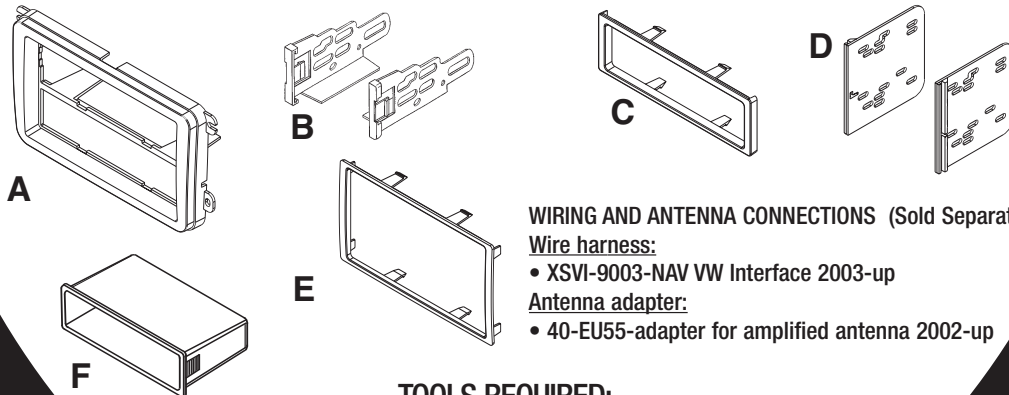

WIRING AND ANTENNA CONNECTIONS (Sold Separately)

Wire harness:

- XSVI-9003-NAV VW Interface 2003-up

Antenna adapter:

- 40-EU55-adapter for amplified antenna 2002-up

TOOLS REQUIRED:

T-20 Torx Screwdriver • Flat Blade Screwdriver Or Panel Removal Tool

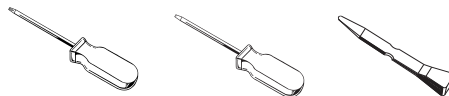

1-800-221-0932



www.metraonline.com

© COPYRIGHT 2004-2009 METRA ELECTRONICS CORPORATION

TABLE OF CONTENTS

• Dash Disassembly

- **GLI 2008-09.....1,2**
- **GTI 2006-09.....1,2**
- **New Jetta 2005-09.....1,2**
- **Rabbit 2006-09.....1,2**
- **R32 2008-09.....1,2**
- **CC 2009 3**
- **Passat 2006-09 3**
- **Tiguan 2009..... 4**
- **Eos 2007-09..... 5**

•Kit Assembly:

- **DIN Head Unit Provision with Pocket6**
- **ISO Head Unit Provision with Pocket7**
- **Double DIN Head Unit Provision.....8**
- **Stacked ISO Head Unit Provision9**

- **Final Assembly10**



KNOWLEDGE IS POWER
Enhance your installation and fabrication skills by enrolling in the most recognized and respected mobile electronics school in our industry. Log onto www.installerinstitute.com or call 800-354-6782 for more information and take steps toward a better tomorrow.

NEW JETTA 2005-09/GLI 2008-09
GTI 2006-09/RABBIT 2006-09
R32 2008-09

- 1** Disconnect the negative battery terminal to prevent an accidental short circuit.
- 2** Unclip and remove the grille from the top-center of dash. (Figure A)
- 3** Remove one T-20 torx screw from black insert from under grille removed in step one. (Figure B)
- 4** Remove insert. (Figure C)
- 5** Remove two T-20 torx screws from under black insert removed in step two. (Figure D)

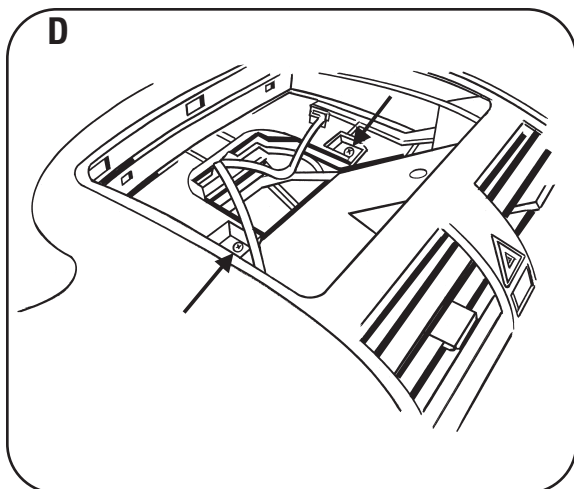
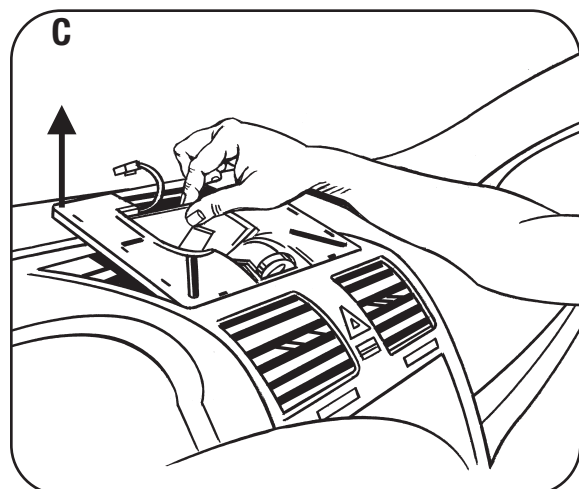
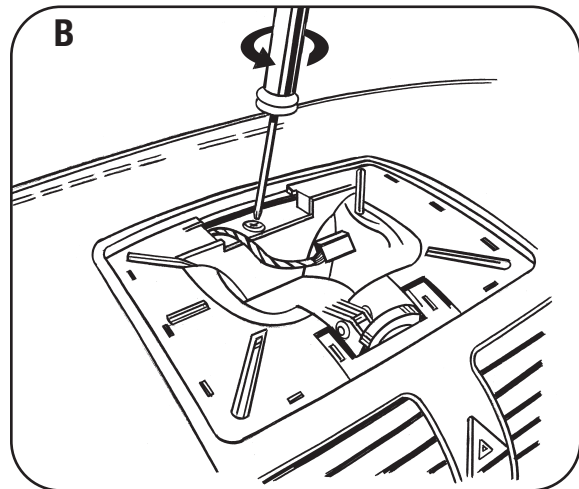
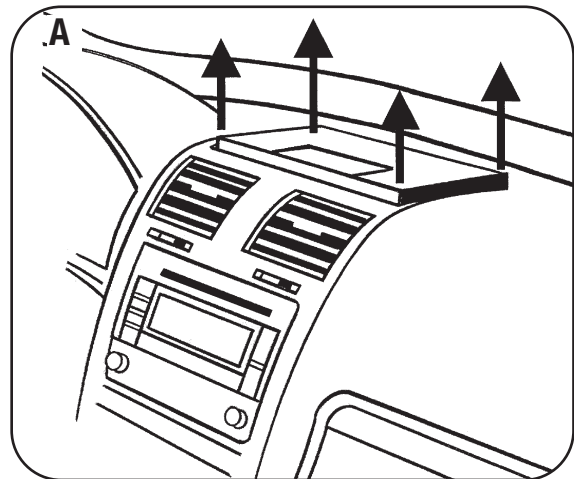

NEW JETTA 2005-09/GLI 2008-09
GTI 2006-08-09/RABBIT 2006-09
R32 2008-09

- 6** Unsnap and remove the vent assembly above the radio. (Figure E)
- 7** Remove two T-20 torx screws from top sides of radio/climate panel. (Figure F)
- 8** Remove panel. (Figure G)
- 9** Remove four T-20 torx screws to remove the radio. (Figure H)

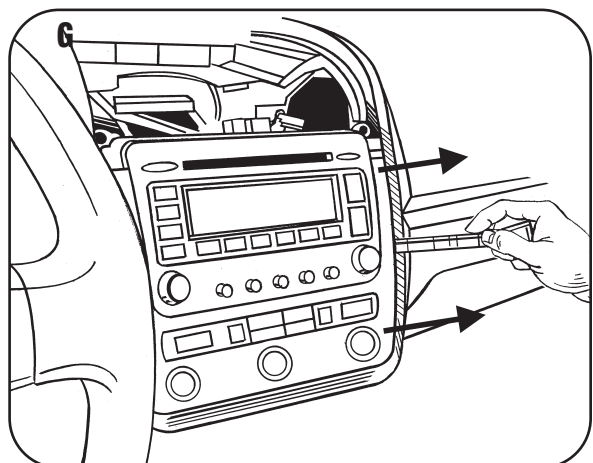
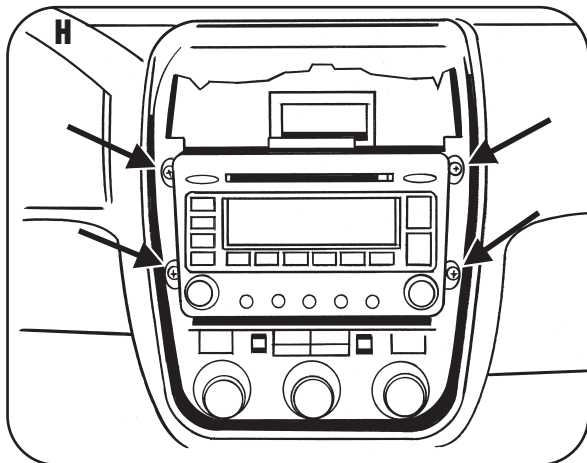
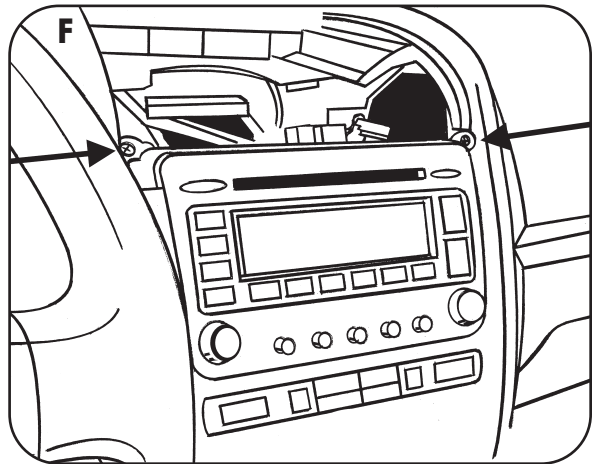
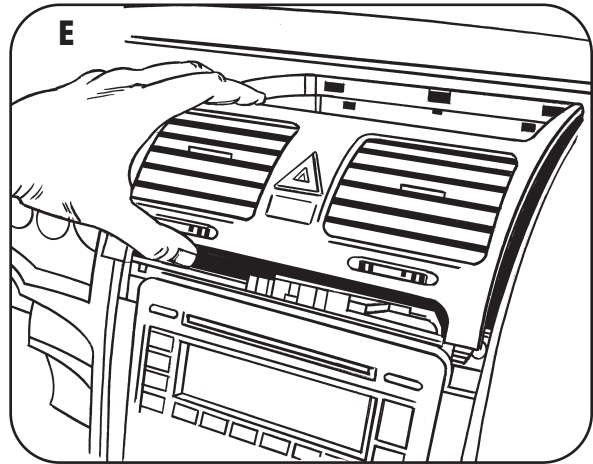

CC 2009 / VW PASSAT 2006-2009

- 1** Disconnect the negative battery terminal to prevent an accidental short circuit.
- 2** Unclip and remove trim panel surrounding radio. **(Figure A)**
- 3** Remove (4) T-20 Torx screws to remove radio.

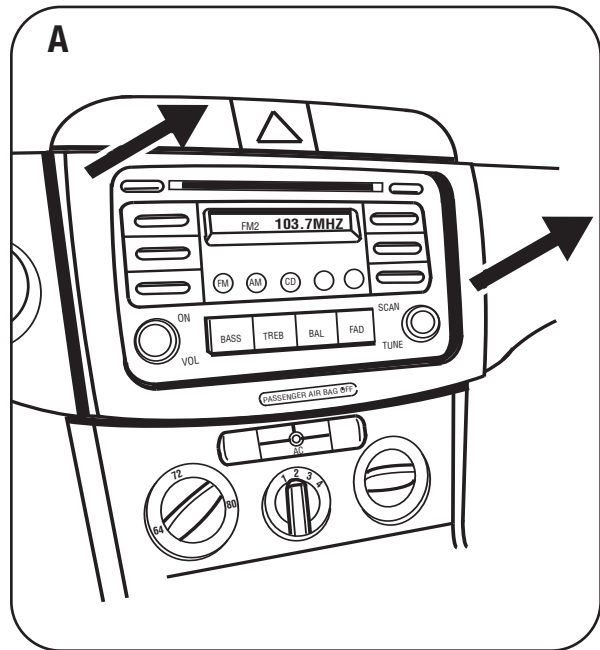

TIGUAN 2009

- 1** Disconnect the negative battery terminal to prevent an accidental short circuit.
- 2** Unclip and remove passenger air bag light panel to the right of the hazard light button. (Figure A)
- 3** Unclip and remove the panel with the two slots in it to the left of the hazard light button. (Figure A)
- 4** Remove (2) T-20 Torx screws exposed behind the two panels removed in the two previous steps. (Figure B)
- 5** Unclip and remove the trim panel surrounding the radio. (Figure C)
- 6** Remove (4) T-20 Torx screws securing the radio. Unplug and remove the radio. (Figure D)

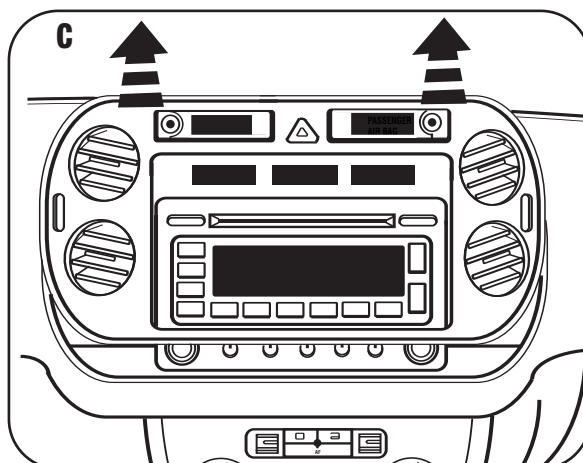
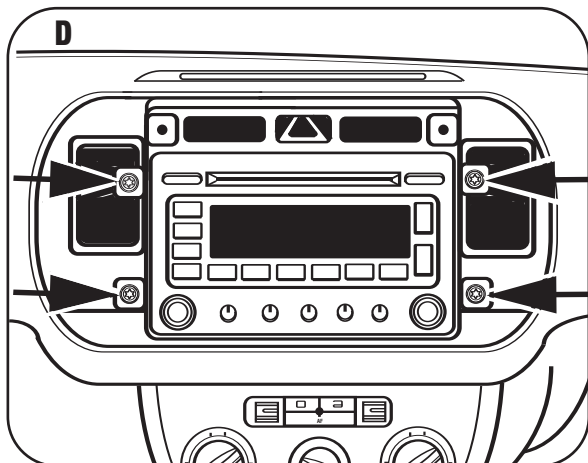
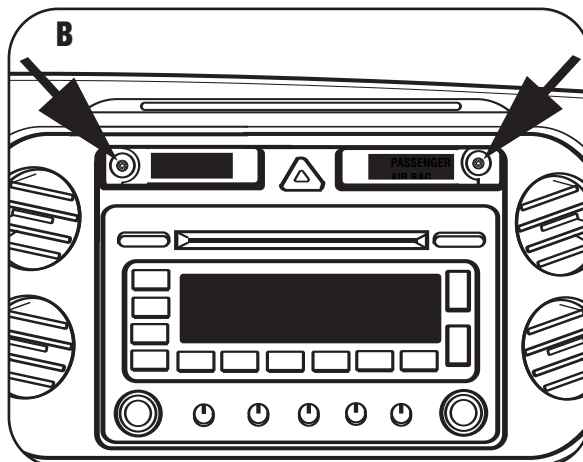
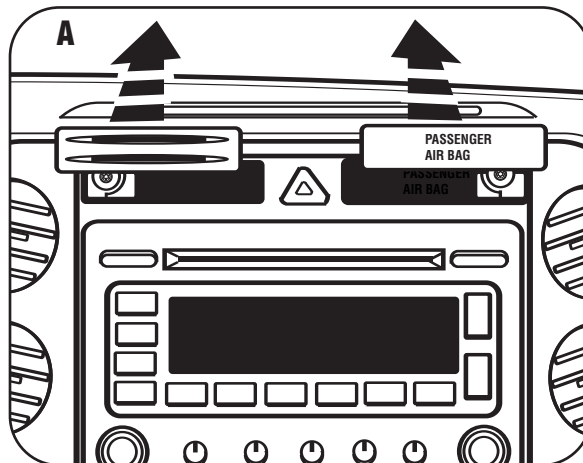

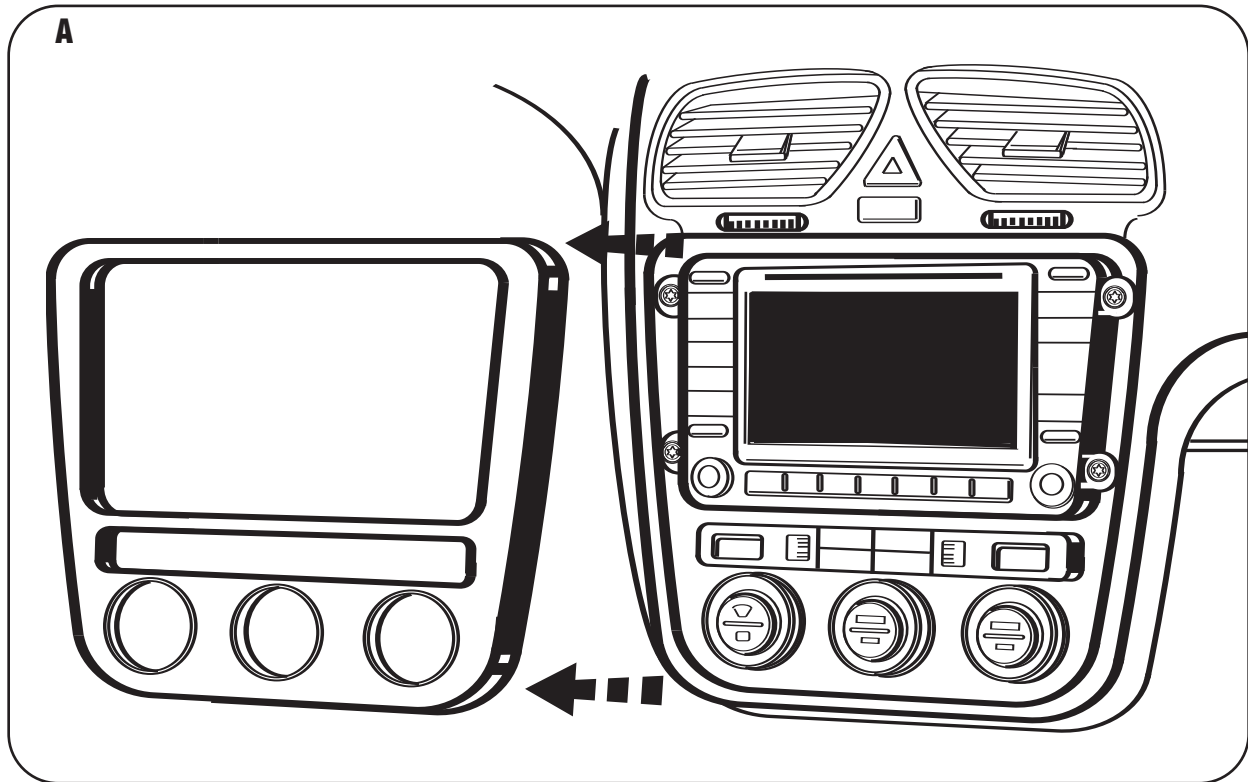
EOS 2007-2009

- 1** Disconnect the negative battery terminal to prevent an accidental short circuit.
- 2** Unclip and remove the radio trim panel. (Figure A)
- 3** Remove the (4) screws securing the radio. Unplug and remove the radio. (Figure B)

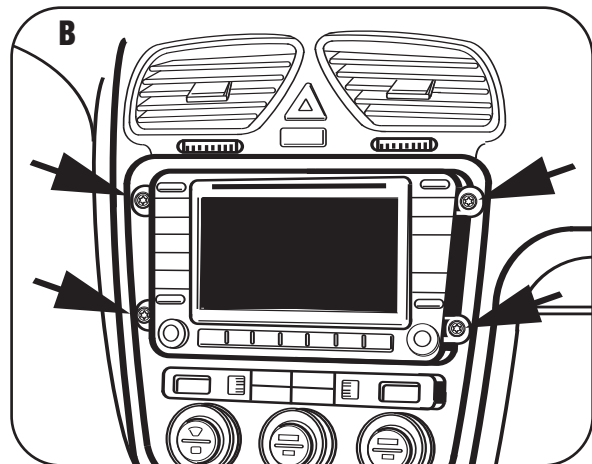

DIN HEAD UNIT PROVISION WITH POCKET

- 1 Slide the DIN cage into the Radio Housing and secure by bending the metal locking tabs down. (Figure A)
- 2 Slide the aftermarket head unit into the cage and secure. (Figure B)
- 3 Snap the pocket into the radio housing. (Figure C)

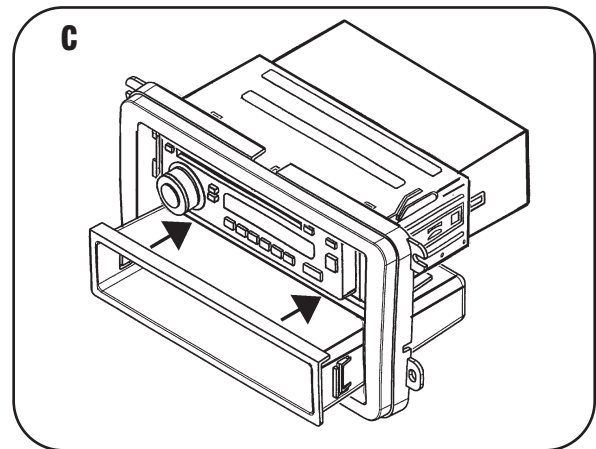
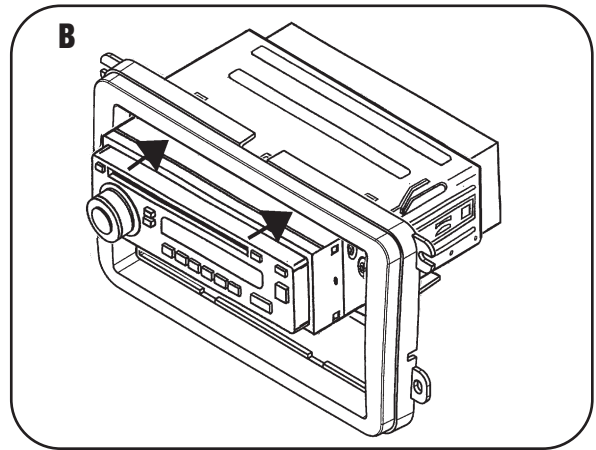
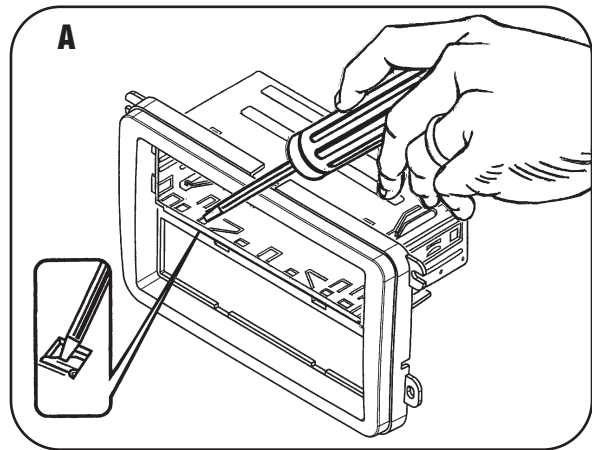

ISO HEAD UNIT PROVISION WITH POCKET

- 1** Mount the ISO Brackets to the head unit with the screws supplied with the unit. **(Figure A)**
- 2** Slide the head unit into the radio opening until the side clips engage. **(Figure B)**
- 3** Snap the ISO Trim Plate into the Radio Housing. **(Figure C)**
- 4** Snap the pocket into the radio housing. **(Figure C)**

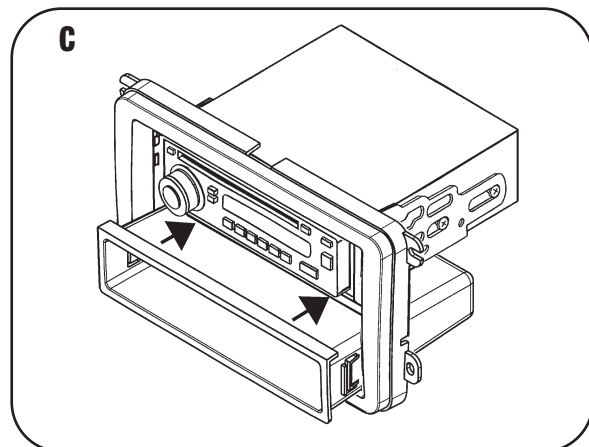
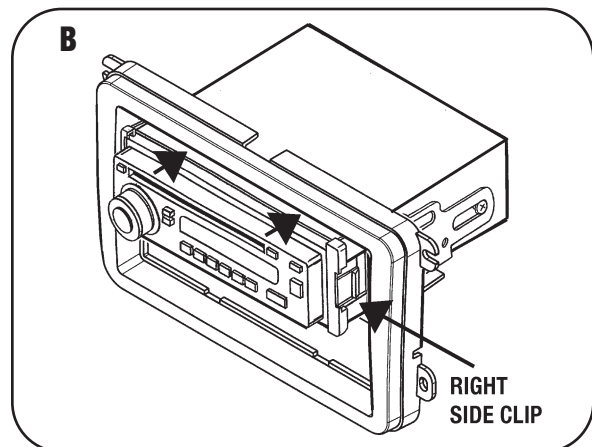
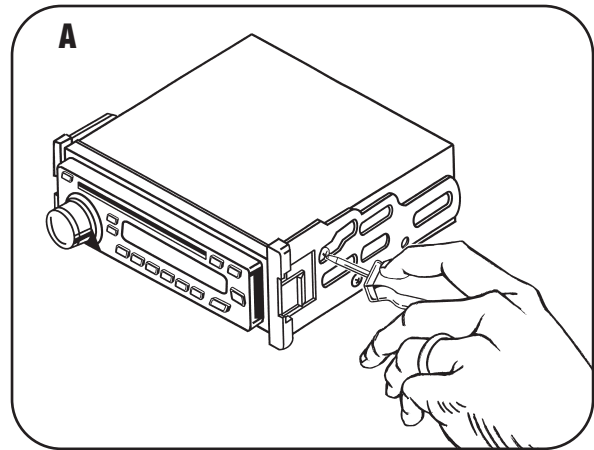

DOUBLE DIN HEAD UNIT PROVISION

- 1 Cut and remove center divide from radio housing. (Figure A)
- 2 Snap the DDIN brackets to the inside edge of the radio housing. (Figure B)
- 3 Slide the DDIN radio unit into the DDIN bracket/radio housing assembly and secure the unit to the kit using the screws supplied with the head unit. (Figure C)
- 4 Snap the DDIN trim-plate onto the housing/radio assembly. (Figure C)

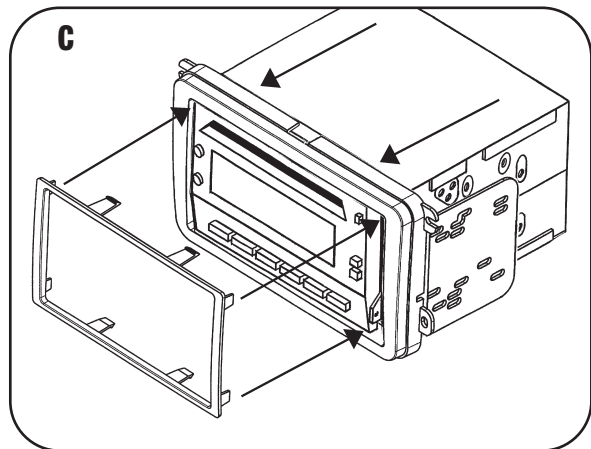
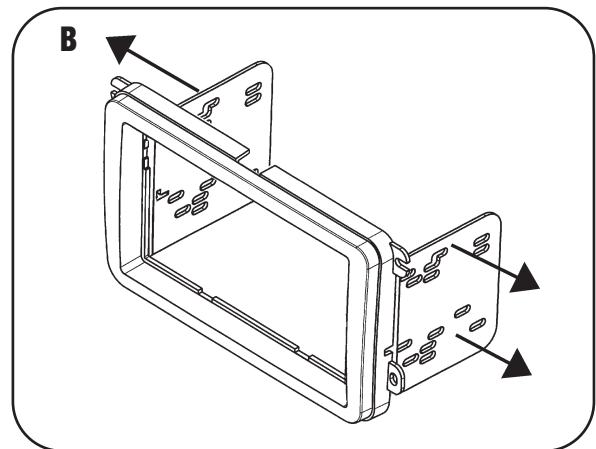
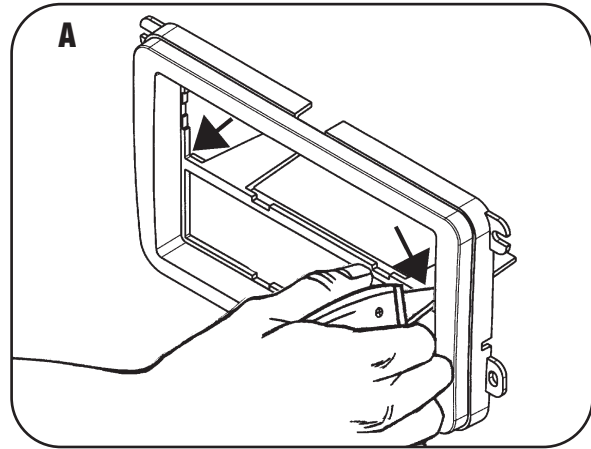

STACKED ISO HEAD UNIT PROVISION

- 1** Cut and remove center divider from radio housing. **(Figure A)**
- 2** Snap the DDIN brackets to the inside edge of the radio housing. **(Figure B)**
- 3** Slide the stacked ISO DIN units into the DDIN bracket/radio housing assembly and secure the units to the kit using the screws supplied with the head units. **(Figure C)**
- 4** Snap the DDIN trim-plate onto the housing/radio assembly. **(Figure C)**

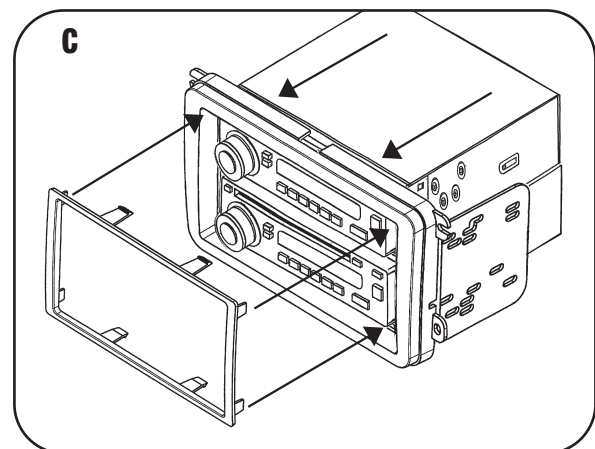
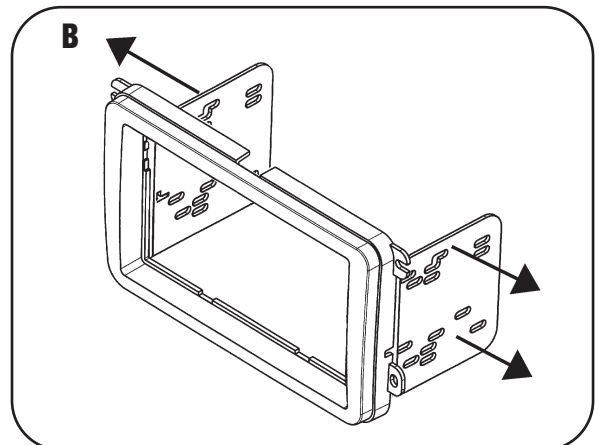
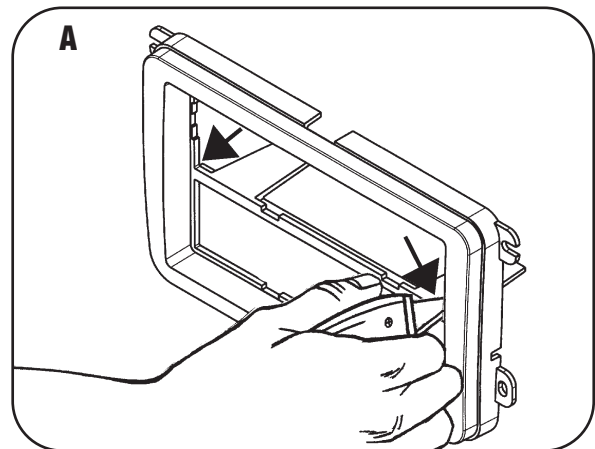

FINAL ASSEMBLY

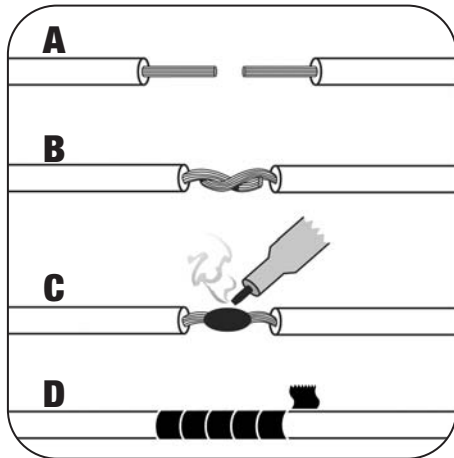

- A) Strip wire ends back 1/2"**
- B) Twist ends together**
- C) Solder**
- D) Tape**

- 1** Locate the factory wiring harness in the dash. Metra recommends using the proper mating adapter and making connections as shown. (Isolate and individually tape off the ends of any unused wires to prevent electrical short circuit.)
- 2** Re-connect the negative battery terminal and test the unit for proper operation.
- 3** Reassemble in reverse order of disassembly.

FINAL WIRING CONNECTIONS

Make wiring connections using the EIA color code chart shown below and the instructions included with the head unit. Metra recommends making connections as shown below; Strip, Splice, Solder, Tape. Isolate and individually tape off ends of any unused wires to prevent electrical short circuit.

METRA / EIA WIRING CODE

12V Ignition / Acc . . . Red	Right Front (+) Gray
12V Batt / Memory . . Yellow	Right Front (-) Gray/ Black
Ground Black*	Left Front (+) White
Power Antenna Blue	Left Front (-) White / Black
Amp Turn-On Blue / White	Right Rear (+) Violet
Amp Ground Black / White	Right Rear (-) Violet / Black
Illumination Orange	Left Rear (+) Green
Dimmer Orange / White	Left Rear (-) Green / Black

***NOTE:** When a Black wire is not present, ground radio to vehicle chassis.
All colors may not be present on all leads due to manufacturer's specifications.



1-800-221-0932



www.metraonline.com