



INSTALLATION INSTRUCTIONS FOR PART 99-7953

APPLICATIONS

Suzuki Grand Vitara 2006-2008

99-7953



KIT FEATURES

- DIN Head Unit Provision with pocket
- ISO DIN Head Unit Provision with pocket

KIT COMPONENTS

A) Radio Housing • B) ISO Brackets • C) Trim Plate

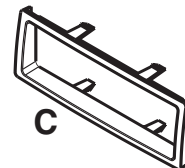
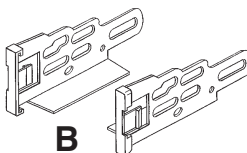
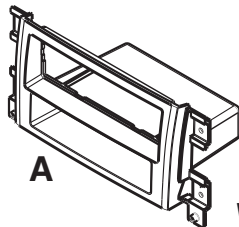

WIRING AND ANTENNA CONNECTIONS (Sold Separately)

Harness:

- **70-1721** - Honda harness 1998-up

Antenna Adapter:

- Not required

TOOLS REQUIRED:

Flat Blade Screwdriver • Phillips Screwdriver • Socket Wrench

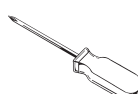
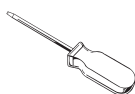

1-800-221-0932



www.metraonline.com

© COPYRIGHT 2004-2009 METRA ELECTRONICS CORPORATION

TABLE OF CONTENTS

Dash Disassembly 1

Kit Assembly 2

Final Assembly 3



KNOWLEDGE IS POWER

Enhance your installation and fabrication skills by enrolling in the most recognized and respected mobile electronics school in our industry. Log onto www.installerinstitute.com or call 800-354-6782 for more information and take steps toward a better tomorrow.

SUZUKI GRAND VITARA 2006-2008

- 1** Disconnect the negative battery terminal to prevent an accidental short circuit.
- 2** Unclip and remove the (2) outside trim panels. (Figure A)
- 3** Remove (6) Phillips screws securing the radio and climate controls to the sub dash. (Figure B)
- 4** Remove the (2) Phillips screws securing the factory radio bracket to the radio/climate control assembly. (Figure C)
- 5** Separate the bracket and factory radio from the climate control. (Figure D)

A

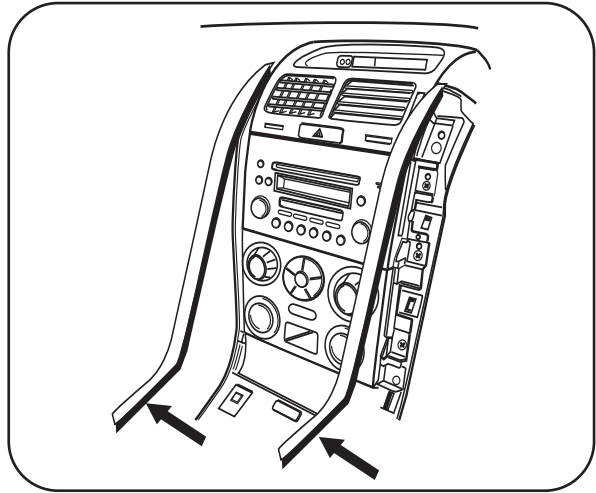

B

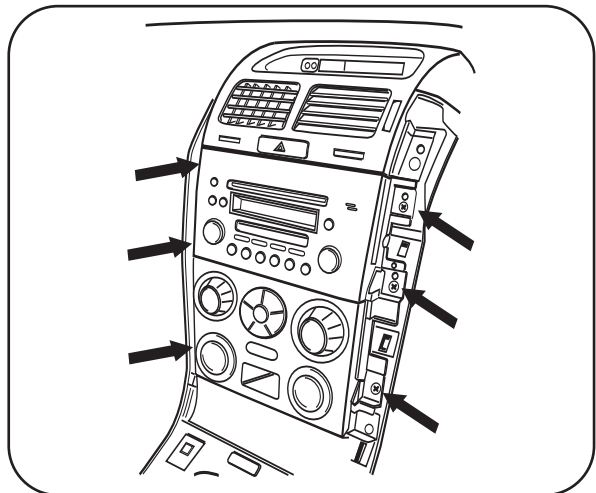

C

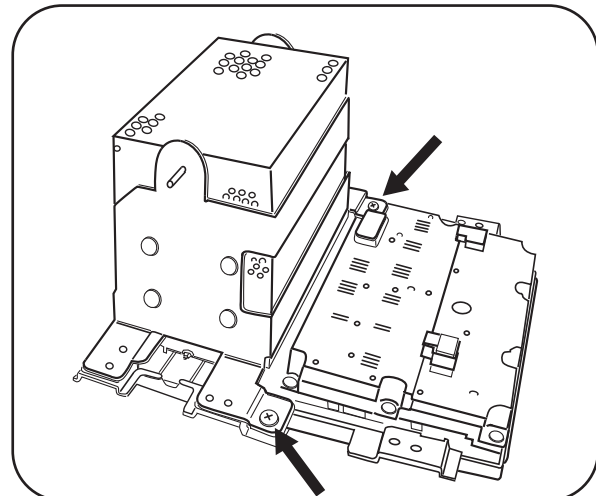

D

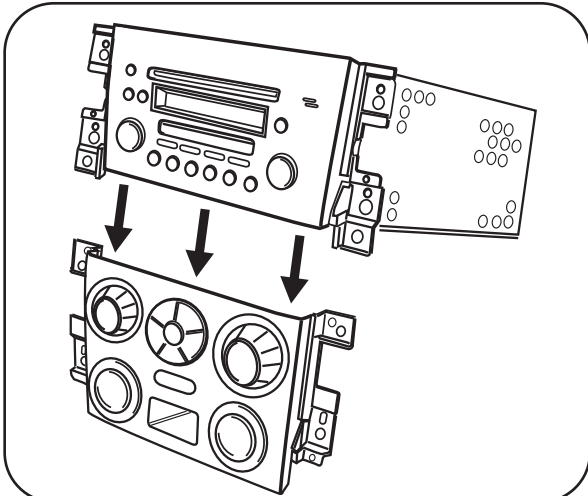

NOTE: Mount the radio housing to the climate control assembly with the factory hardware

DIN HEAD UNIT PROVISION

- 1 Slide the DIN cage into the Radio Housing and secure by bending the metal locking tabs down. (Figure A)

A

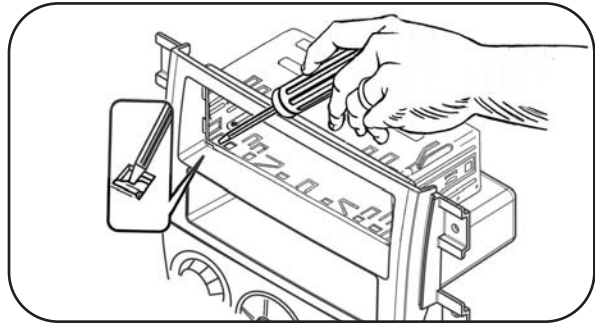

- 2 Slide the aftermarket head unit into the cage until secure. (Figure B)

B

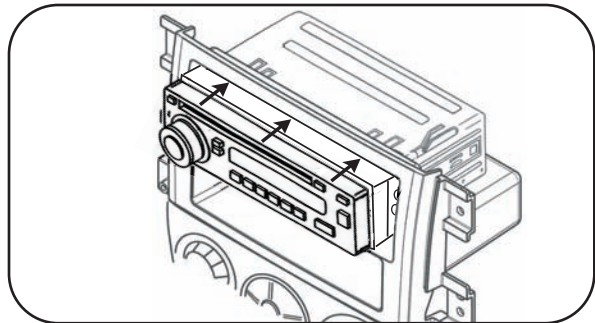

ISO DIN HEAD UNIT PROVISION

- 1 Mount the ISO Brackets to the head unit with the screws supplied with the unit. (Figure A)
- 2 Slide the head unit into the radio opening until the side clips engage. (Figure B)
- 3 Snap the Trim plate into the Radio Housing. (Figure B)

A

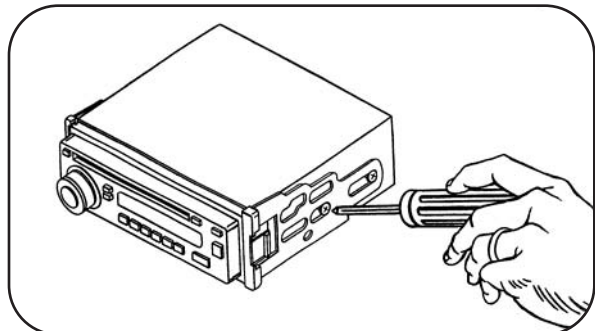

B

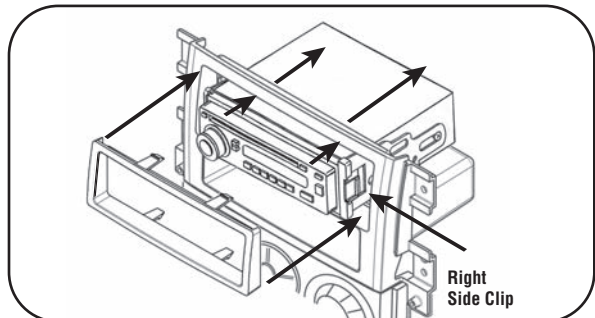

FINAL ASSEMBLY

- 1 Locate the factory wiring harness in the dash and make the connection as shown. Metra recommends using the proper mating adapter and making the connections as shown. (Isolate and individually tape off the ends of any unused wires to prevent electrical short circuit.)
- 2 Re-connect the negative battery terminal and test the unit for proper operation.
- 3 Reassemble radio and dash assemblies in reverse order of disassembly.

FINAL WIRING CONNECTIONS

Make wiring connections using the EIA color code chart shown below and the instructions included with the head unit. Metra recommends making connections as shown below; Strip, Splice, Solder, Tape. Isolate and individually tape off ends of any unused wires to prevent electrical short circuit.

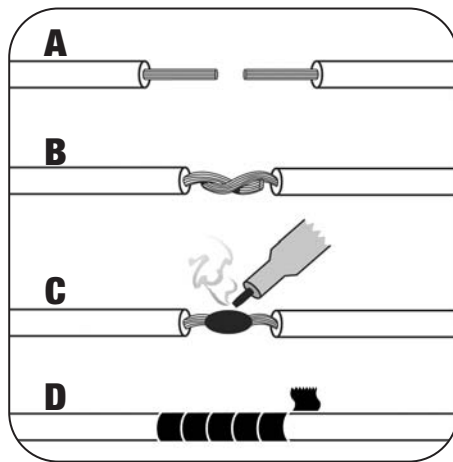

- A) Strip wire ends back 1/2"**
- B) Twist ends together**
- C) Solder**
- D) Tape**

METRA / EIA WIRING CODE

12V Ignition / Acc . . . Red	Right Front (+) Gray
12V Batt / Memory . . . Yellow	Right Front (-) Gray / Black
Ground Black*	Left Front (+) White
Power Antenna Blue	Left Front (-) White / Black
Amp Turn-On Blue / White	Right Rear (+) Violet
Amp Ground Black / White	Right Rear (-) Violet / Black
Illumination Orange	Left Rear (+) Green
Dimmer Orange / White	Left Rear (-) Green / Black

***NOTE:** When Black a wire is not present, ground radio to vehicle chassis.

All colors may not be present on all leads due to manufacturer's specifications.

99-7953 INSTRUCTIONS



1-800-221-0932



www.metraonline.com

REV. 06/30/09

© COPYRIGHT 2004-2009 METRA ELECTRONICS CORPORATION

INST99-7953